



# CM 18-09 | Miss That Kind of Clarity

RULES: USPSA Handgun Competition Rules, current edition. Course Designer: Nationals Design Team

## STAGE PROCEDURE

**Strings 1 and 2:** On the audible start signal, engage any 3 targets with only 2 rounds each, perform a mandatory reload, and engage remaining 3 targets with only 2 rounds each from within the shooting area.

**Scoring:** Virginia, 24 rounds, 120 points  
**Targets:** 6 USPSA Targets  
**Scored Hits:** Best 4/paper  
**Start - Stop:** Audible - Last Shot  
**Penalties:** Per current edition of USPSA Handgun Competition Rules.

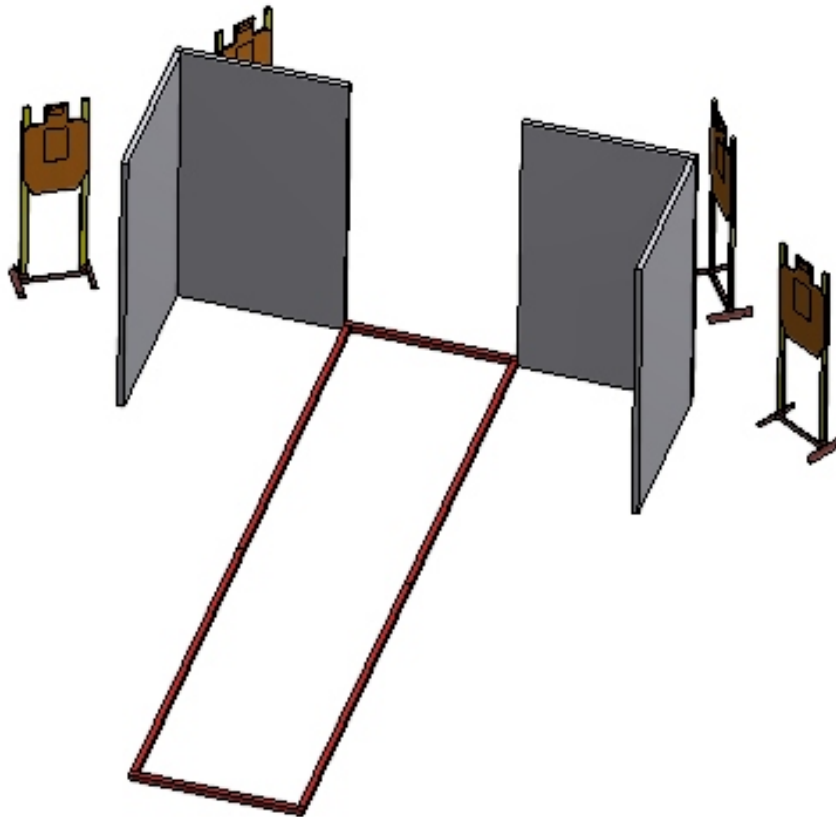
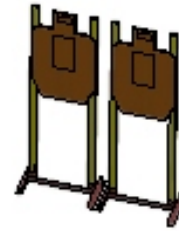

**SETUP NOTES:** Set targets 5 feet to top.

**MATERIALS LIST:** (4) 4 ft x 6 ft or more walls, (4) 2 x 2 x 8 ft fault lines  
(2) 2 x 2 x 4 ft fault lines, (6) Target Stands  
(12) 1 x 2 x 5 ft Target Sticks, (6) USPSA Targets



## CM 18-09 | Miss That Kind of Clarity

I Miss That Kind Of Clarity is a 24 round, 120-point, Virginia Count Standard Exercise. There are 6 USPSA targets. The best 4 hits per paper will score.

The handgun start position is standing inside shooting area, with heels on rear fault line for String 1 and toes on front fault line for String 2, wrists below belt with handgun loaded and holstered.

The PCC start position is standing inside shooting area, with heels on rear fault line for String 1 and toes on front fault line for String 2, holding loaded PCC, stock on belt, and muzzle pointing downrange.

String 1 and 2: On the audible start signal from within shooting area, engage any 3 targets with only 2 rounds each, perform a mandatory reload, and engage remaining 3 targets with only 2 rounds each.





# CM 18-09 I Miss That Kind of Clarity

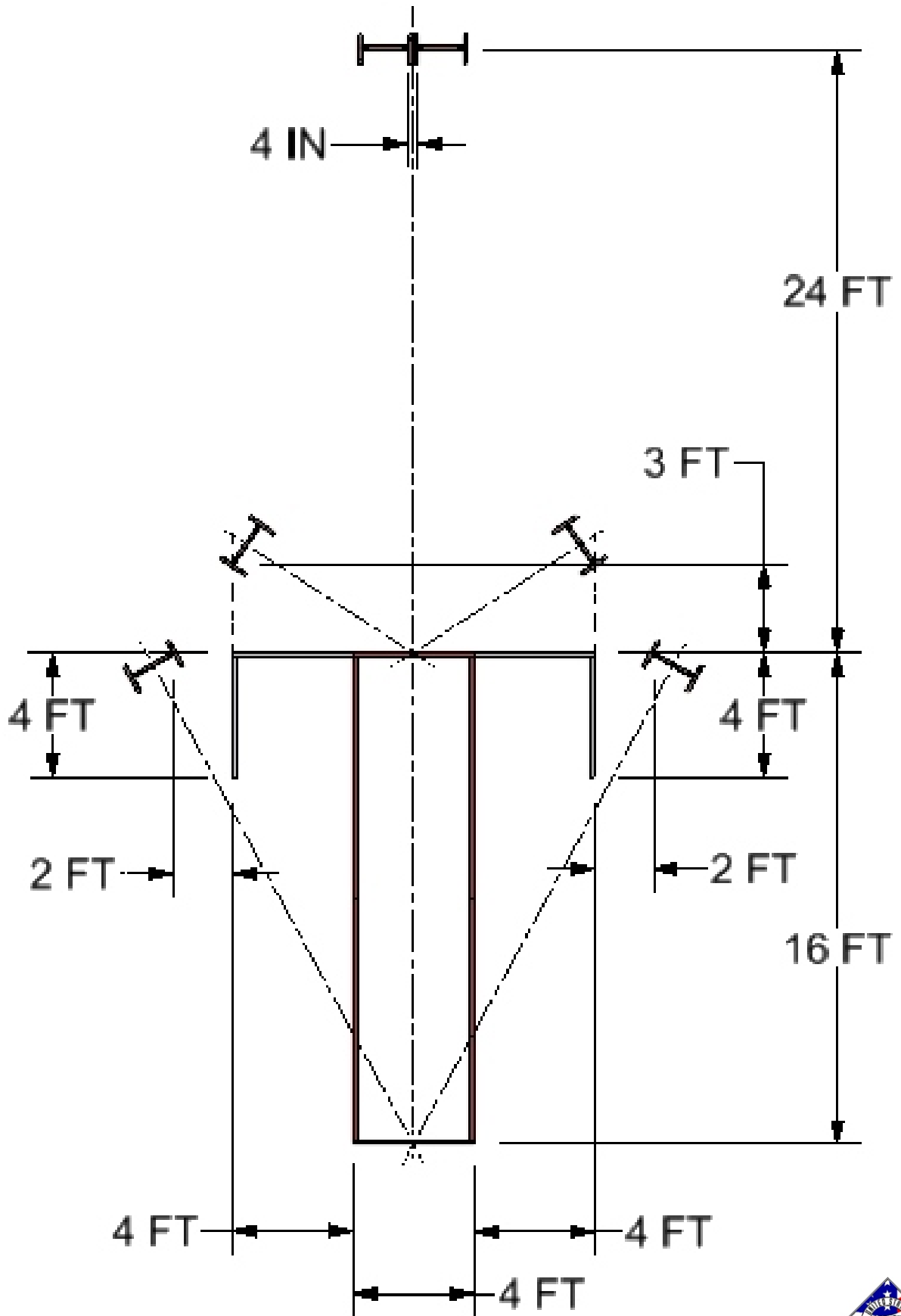



# CM 18-09 I Miss That Kind of Clarity

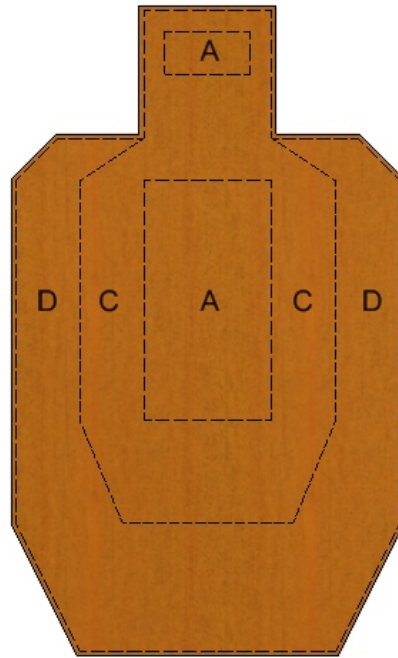

All Targets are USPSA





# Stage 2

# Swiped

**RULES:** Practical Shooting Handbook, Latest Edition    **COURSE DESIGNER:** Bud Connolly

**START POSITION:** Standing facing downrange with toes on either set of marks. Handgun is loaded and holstered. PCC is loaded with safety on and held in both hands, shouldered with muzzle pointed at cone on opposite side of shooting area.

### STAGE PROCEDURE

On signal, engage T1-T11 with two rounds each from within the shooting area.

### SCORING

**SCORING:** Comstock, 22 rounds, 110 points  
**TARGETS:** 11 USPSA  
**SCORED HITS:** Best 2 per USPSA  
**START-STOP:** Audible - Last shot  
**PENALTIES:** Procedural. -10  
Miss. -10

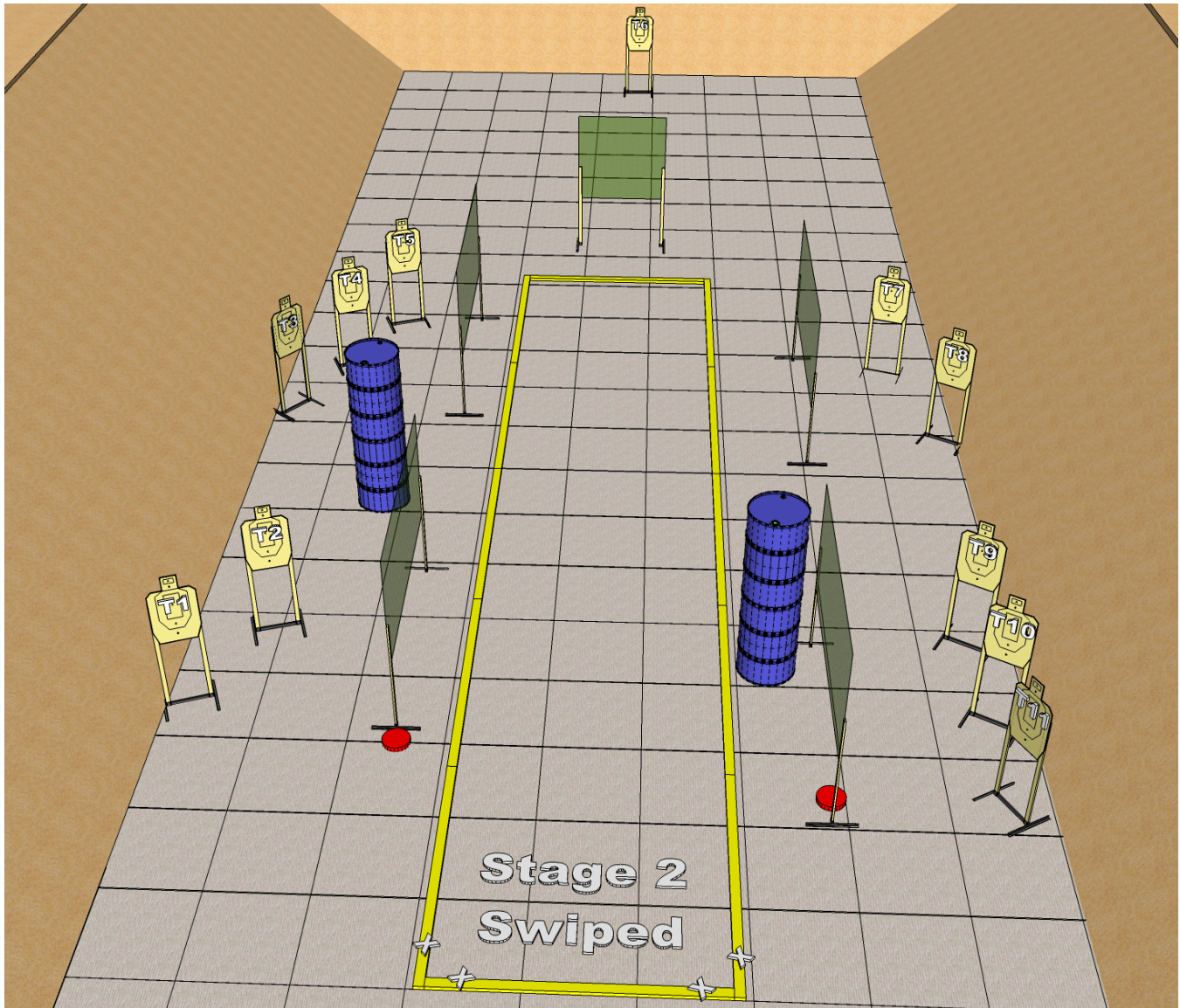

**SETUP NOTES:** Ensure targets are behind a wall and cannot be engaged past the 180. T6 and the far wall are set to force the shooter to one of the front corners to engage.

**RO NOTES:** Watch for foot faults.



# Stage 3

# Stolen

**RULES:** Practical Shooting Handbook, Latest Edition **COURSE DESIGNER:** Bud Connolly

**START POSITION:** Standing facing downrange with heels on either start stick and wrists below belt. Handgun is loaded and holstered.  
PCC is loaded with safety on and held in both hands, with butt on belt and muzzle pointed at cone.

### STAGE PROCEDURE

On signal, engage T1-T10 with two (2) rounds each and knock down P1-P3.

### SCORING

**SCORING:** Comstock, 23 rounds, 115 points  
**TARGETS:** 10 USPSA, 3 Poppers  
**SCORED HITS:** Best 2 per USPSA, steel down = 1A  
**START-STOP:** Audible - Last shot  
**PENALTIES:** Procedural. -10  
Miss. -10

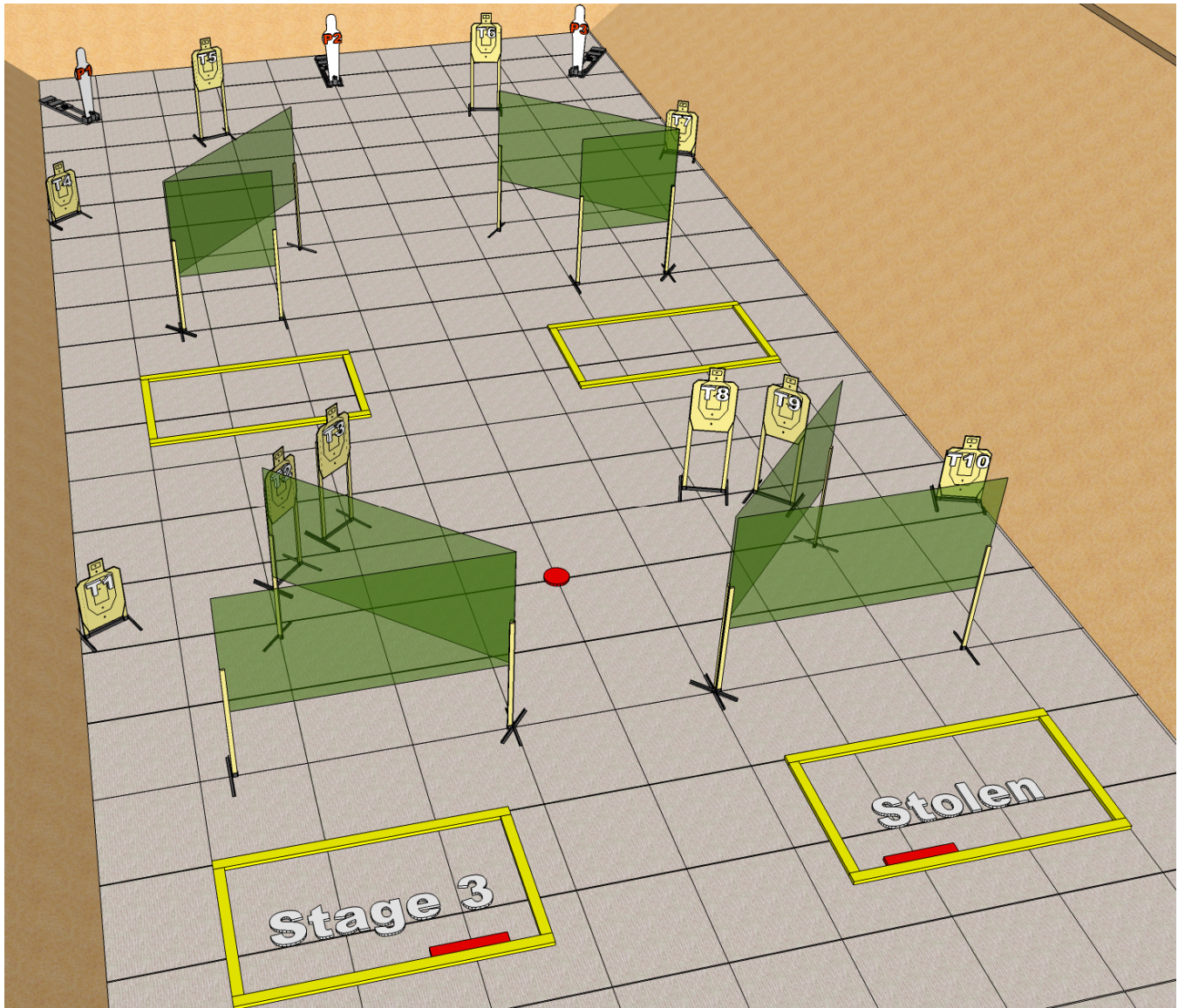

**SETUP NOTES:** Setup targets and walls as shown (use the 3' grid!). P1 & P2 should be available from their respective sides and through the middle. P2 should also be available from the strong side shooting box near the berm.

**RO NOTES:** Watch for foot faults.



# Stage 4

# Pilfered

**RULES:** Practical Shooting Handbook, Latest Edition    **COURSE DESIGNER:** Bud Connolly

**START POSITION:** Standing facing downrange with heels on start stick and wrists below belt. Handgun is loaded and holstered.

PCC is loaded with safety on and held in both hands, with butt on belt and muzzle pointed at cone.

### STAGE PROCEDURE

On signal, draw and engage T1-T12 with two (2) rounds each and knock down P1-P3.

### SCORING

**SCORING:** Comstock, 27 rounds, 135 points

**TARGETS:** 12 USPSA, 3 Poppers

**SCORED HITS:** Best 2 per USPSA, steel down = 1A

**START-STOP:** Audible - Last shot

**PENALTIES:** Procedural. -10

No-shoot hit. -10

Miss. -10

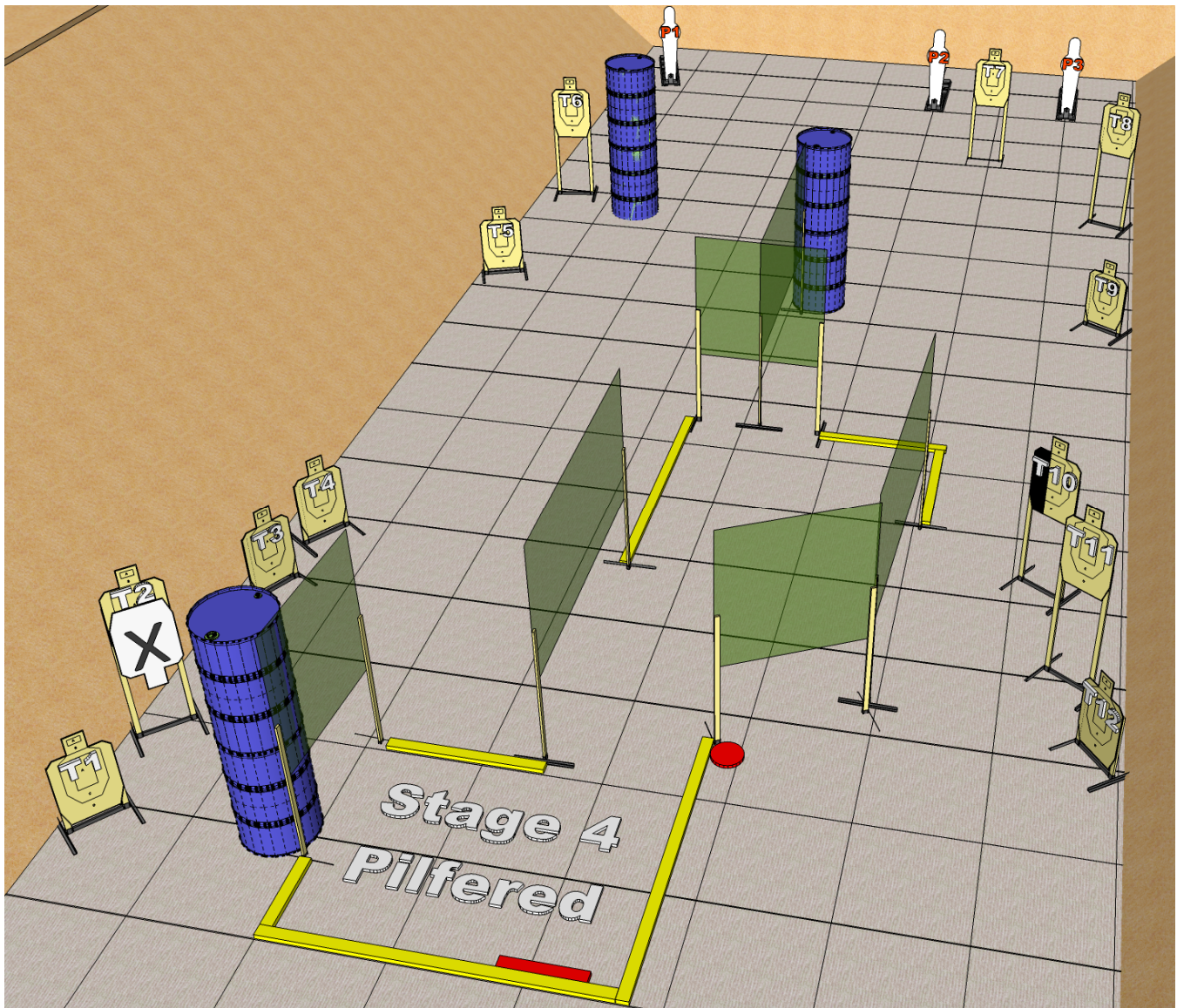

**SETUP NOTES:** Barrels block T3-T4 from left rear corner.  
Barrels block P1 from rear left opening. And right front barrels  
block P1 from right front opening.

**RO NOTES:** Watch for foot faults.



# Stage 5

# Hijacked

**RULES:** Practical Shooting Handbook, Latest Edition **COURSE DESIGNER:** NISA

**START POSITION:** Standing with toes touching the start stick on either side. Handgun is loaded and holstered.  
PCC is loaded with safety on and held in both hands, with butt on belt and muzzle pointed safely downrange.

### STAGE PROCEDURE

On signal, engage T1-T9 with two (2) rounds each and knock down MP1-MP3.

### SCORING

**SCORING:** Comstock, 21 rounds, 105 points  
**TARGETS:** 9 USPSA, 3 Mini-Poppers  
**SCORED HITS:** Best 2 per USPSA, steel down = 1A  
**START-STOP:** Audible - Last shot  
**PENALTIES:** Procedural. -10  
No-shoot hit. -10  
Miss. -10

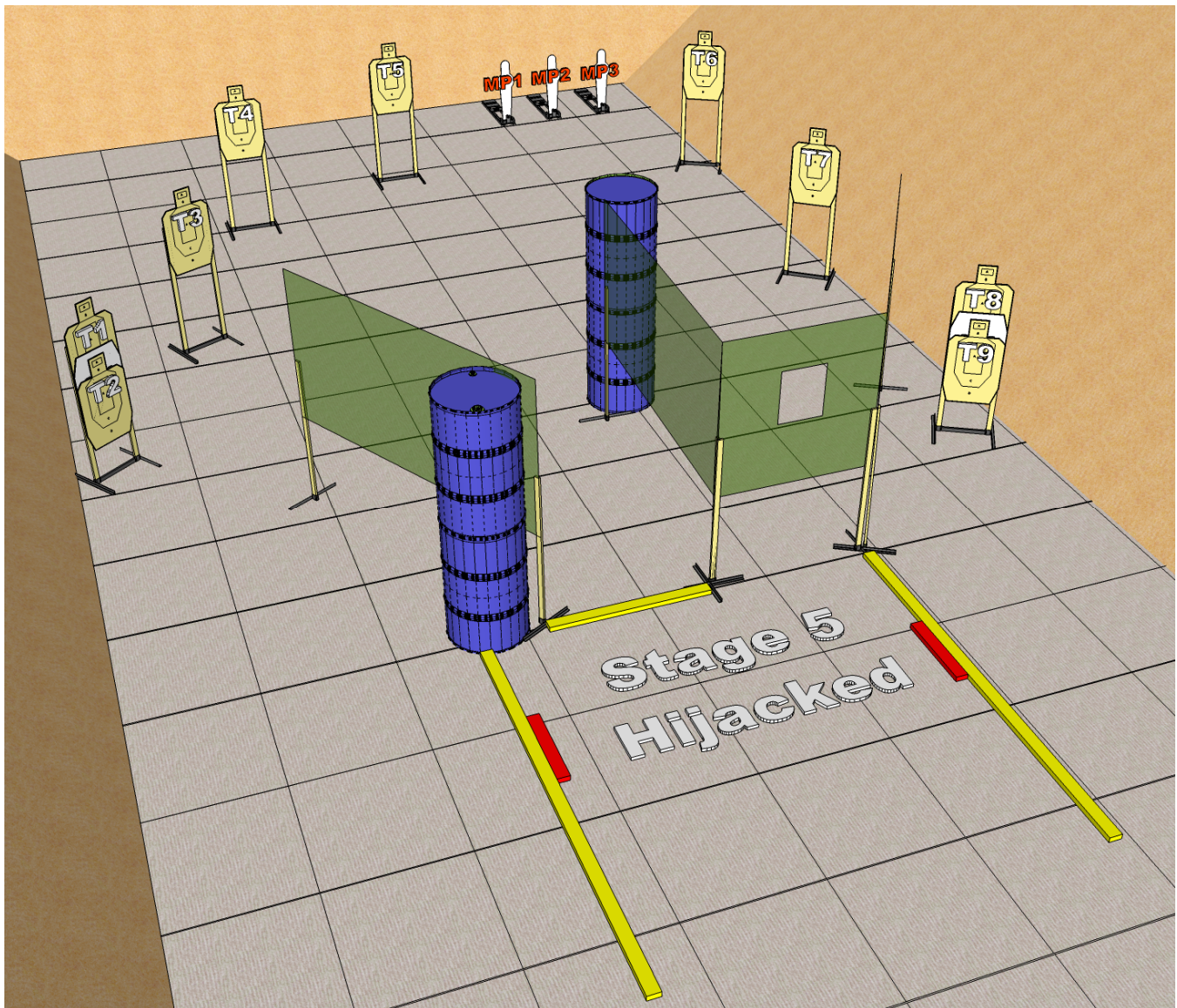

**SETUP NOTES:** Set MP1- MP3 so that they are only visible through the port.

**RO NOTES:** Watch for foot faults.



# Stage 6

# Taken

**RULES:** Practical Shooting Handbook, Latest Edition    **COURSE DESIGNER:** Ed Henry

**START POSITION:** Standing directly behind barrel with palms flat on top of barrel. Handgun is loaded and holstered. PCC is loaded with safety on and held in both hands, with butt on belt and muzzle touching top of barrel.

### STAGE PROCEDURE

On signal, engage T1-T8 with two (2) rounds each and knock down USPSA Popper P1 & P2 and five (5) Plates.

### SCORING

**SCORING:** Comstock, 23 rounds, 115 points  
**TARGETS:** 8 USPSA, 2 Poppers, 5 Plates  
**SCORED HITS:** Best 2 per USPSA, steel down = 1A  
**START-STOP:** Audible - Last shot  
**PENALTIES:** Procedural. -10  
No-shoot hit. -10  
Miss. -10

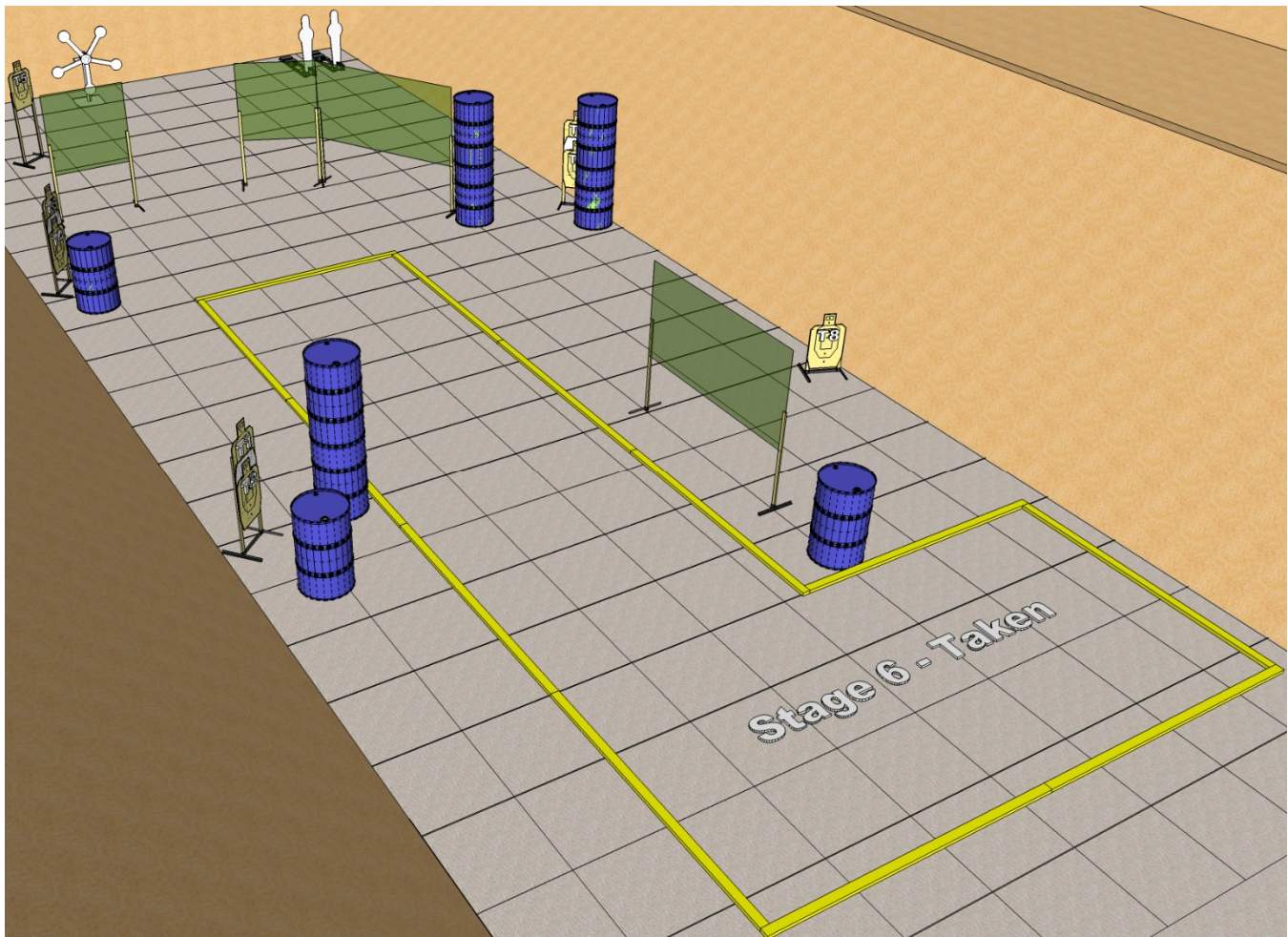

**SETUP NOTES:** Place Texas Star as close to rear berm as possible. Set forward fault line 8 yards from star. T5 should be placed to only be visible from the far-right front corner. Place double targets (T1/T2, T3/T4 & T6/T7) as low as possible on stand with one inch of No Shoot placed between the targets with only the upper A zone visible above the barrel. Targets T1-T4 & T6-T8 are placed as close as possible to the side berm. Start barrel is touching the fault line in line with the 8' wall set 3' from the right-side fault line. Barrels should completely block T6/T7 from the rear right side shooting area.

**RO NOTES:** None